



H-900 SERIES RELIEF VALVES

INTRODUCTION

The H-900 Series Relief Valves are designed and tested in accordance with MSS standard SP-99-1994 (R2005) - (Instrument Valves). This type of valves is intended for use under relatively low operating pressures (ranging from 10 psig to 225 psig), in unfavorable working conditions and can be implemented in either gas or liquid applications. The valves are manufactured from ASTM-A276 body construction and are available in male and female NPT / BSPT pipe threads and LET-LOK (compression) connectors.

General

H-900 series is a relief valve intended for use in low-pressure applications. The valve is normally closed and opens when the system pressure reaches a set level. It then returns to the closed position when the system pressure falls below the set level.

Features

- Made from St.St 316.
- Service pressure up to 300psig.
- Available set pressures between 10 psig and 225 psig (0.69 to 15.5 Bar).
- Available in male and female NPT / BSPT pipe threads and Let-Lok (compression) connectors.
- Available sizes: 1/4" or 6mm.

Cleaning & Packaging

Every H-900 series Relief valve is cleaned in accordance with Standard Cleaning and Packaging (procedure 8184). Oxygen Clean & Lubricant Free Cleaning and packaging, in accordance with Special Cleaning and Packaging (procedure 8185), is available as an option.

Testing

The designs of the HAM-LET H-900 Series Relief Valves have been tested for proof, burst and leakage. Every relief valve is factory-tested for proper set and resealing performance.

SAFETY INSTRUCTIONS

General

- All installation and/or maintenance operations must be obtained when the system pressure is fully relieved.
- All installation and/or maintenance operations must follow User Manual Instructions.
- Use only appropriate tools, which are designed and built for the specific operation.
- Plan your action carefully in advance, especially when dealing with extreme temperature, pressure and corrosive materials.
- Use proper protection and safety devices during maintenance.

Volume Considerations

While evaluating the volume to be relieved, all system volumes should be considered, i.e.: system lines, pumps, bulk tanks, etc.

Oxygen Applications

For oxygen applications, work shall be carried out according to the procedures for working with oxygen. In a case where spare kits are ordered for oxygen clean valves, such kits have to be ordered as "oxygen clean" by adding the "- OC" designator. Example: Z-900-SK-1/4-VI-OC

Warning!

The system designer and user have the sole responsibility for selecting products suitable for their special application requirements, ensuring their safe and trouble-free installation, operation, and maintenance. Application details, material compatibility and product ratings should all be considered for each selected product. Improper selection, installation or use of products can cause property damage or personal injury.

All safety valves which are intended to be used by 'end users' located within the European Community must be 'CE' marked. The distributor of the valves bears the responsibility for the follow-up of the above-mentioned issue, in case he is not the 'end user'.



H-900 SERIES (Cont'd) RELIEF VALVES

H-900 - MATERIALS

No.	Part	Qty.	Valve Body Material
1	Cap Plug	1	Polypropylene
2	Adjustment Cap	1	St.St. 316
3	Cap Lable	1	Polyester
4	Spring	1	St.St. 302
5	Locking Nut	1	St.St. 316
6	Spring Support Disc	1	St.St. 316
7	Bonnet	1	St.St. 316
8	O-Ring	1	Fluorocarbon FKM
9	Stem	1	St.St. 316
10	O-Ring	1	Fluorocarbon FKM
11	Retaining Ring	1	PH1-57 Mo
12	Poppet	1	St.St. 316
13	Seal	1	Fluorocarbon FKM
14	Insert	1	St.St. 316
15	Packing	1	PTFE
16	Ring	1	St.St. 316
17	Body	1	St.St. 316

DIMENSIONS

Description	Connection / size		Dimensions mm:			
	inlet	outlet	H	N	S	L
H900	1/4 LET-LOK®	1/4 LET-LOK®	37	39	50	105
H900	6MM LET-LOK®	6MM LET-LOK®	37	39	50	105
H985	1/4 Male NPT	1/4 Female NPT	32	30	40	100
H995	1/4 Male NPT	1/4 LET-LOK®	32	39	50	100

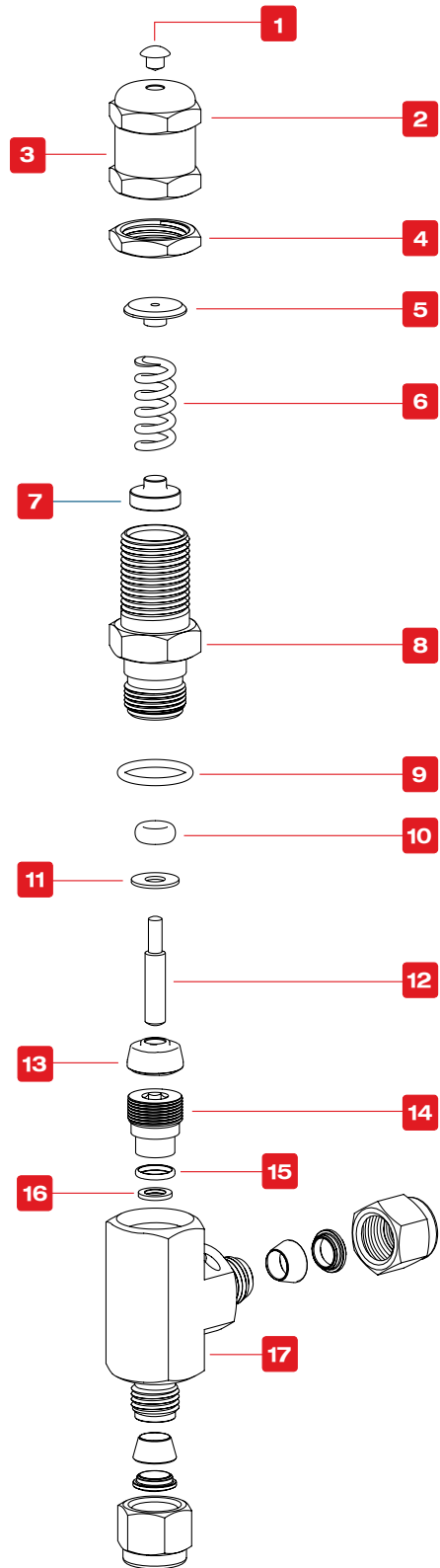
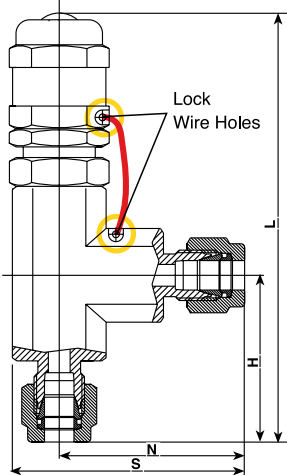



H-900 SERIES (Cont'd) RELIEF VALVES

MAINTENANCE

Tool Requirement

- 3/4" wrench.
- 5/16" Allen (Hex) key.
- O-ring installation and removal tools.
- Retaining ring installation and removal tool.

Cracking Pressure Adjustment

1. Thread the adjustment cap (3) onto the bonnet (7) - 9 full turns.
2. Tighten the locking nut (5) against the adjustment cap (2) and test for set pressure.
3. Relieve the system pressure; unthread the adjustment cap (2) as needed (use the manual or a 3/4" wrench). Repeat the procedure as necessary to obtain the desired set pressure.
 - 3.1 A clockwise rotation of the adjustment cap (2) will increase the spring force and the cracking pressure of the valve.
 - 3.2 A counter-clockwise rotary of the adjustment cap (2) will decrease the spring force and the cracking pressure of the valve.
4. Tighten the locking nut (5) against the adjustment cap (2).
5. Lock wire the adjustment cap (2) and the valve body (17) to maintain the relief setting.

H-900 Series - Spring Installation / Replacement

Warning: Relieve the system pressure before any valve maintenance.

Content:

- 1 x Spring (4)
- 1 x Label (3)
- 1 x Lock wire
- 1 x Lead

1. Select the desired spring according to the Nominal Cracking Pressure Range as shown at the "material of construction" section above.
2. Loosen the locking nut (5) with a 3/4" wrench (clockwise) and remove the adjustment cap (2) with a 3/4" wrench (counter-clockwise) from the bonnet (7).
3. Remove the spring (4).
4. Make sure all of the components are clean of burrs.
5. Insert the selected spring (4) inside the bonnet (7).

6. Replace the existing cracking pressure range label (3) with a new one. Ensure that the pressure range, which is written on the Label (3), is in compliance with the installed spring (4) range.
7. Screw the adjustment cap (2) onto the bonnet (7) with a 3/4" wrench.
8. Perform the Cracking Pressure Adjustment procedure described above.

Valve Testing Guidelines.

1. Connect the Relief Valve inlet to the pressure source.
2. Connect the Relief Valve outlet to any leak detecting device.
3. Increase the inlet pressure slowly.
4. Verify that an initial flow from the outlet will occur at the pre-set pressure.
5. Repeat the adjustment procedure as necessary to set the desired cracking pressure.

Note:

For proper maintenance of the H-900 Series Relief Valves, a service cycle and setting validation of at least once each 1/2 year is recommended. The inspection, maintenance and testing can be incorporated into the annual inspection procedure to ensure proper operation and many years of trouble-free service.

The life span of the main valve seal depends upon varied factors, such as:

- Chemical resistance of the seal to the system medium
- The volume of fluid, passed through the valve.
- The operating pressure
- The quantity of dirt and other foreign particles present.

H-900 SERIES SEAL KIT REPLACEMENT.

Content:

- 1 x O-ring (8)
- 1 x O-ring (10)
- 1 x Retaining ring (11)
- 1 x Bonded poppet (12)

Oxygen Applications

For oxygen applications, work shall be carried out according to the procedures for working with oxygen. In a case where spare kits are ordered for "oxygen clean" valves, such kits have to be ordered as oxygen clean by adding the "-OC" designator. Example: Z-900-SK-1/4-VI-OC



H-900 SERIES (Cont'd) RELIEF VALVES

Disassembly and Seal Removal

Warning: Relieve the system pressure before any valve maintenance.

1. Clamp the valve body in a vise.
2. Remove the adjustment cap (2).
3. Remove the bonnet (7) from the body (17) - use a 3/4" wrench and rotate counter-clockwise for opening.
4. Remove stem (9) by pulling it from the bonnet (7) bore.
5. Remove the O-ring (8) from the bonnet (7).
6. Remove carefully the retaining ring (11) from the bonnet (7).
Caution: The retaining ring is a spring stainless clip. Do not direct it at a person.
7. Remove the O-ring (10) from the bonnet (7).
8. Remove the bonded poppet (12) by turning the valve upside down.
9. Discard all soft (wetted) parts.
10. Inspect all parts for nicks, scratches and dents. Discard as appropriate. Replace with HAM-LET parts only.

Reassembly And Seal Installation

1. Clamp the valve body in a vise.
2. Make sure all parts are clean before installation.
3. Install a new bonded poppet (12) in the body (7) (upright position), when the seal of the bonded poppet is faced downward.
4. Install a new O-ring (10) (lubricate with system compatible lubricant) into the bonnet (7).
5. Install new retaining ring (11) (make sure the teeth are pointing away from the quad-ring).
6. Insert the stem (9) into the bonnet (7) through o-ring (9) until it bottoms.
7. Install new o-ring (8) on the bonnet (7) (Lubricate with system compatible lubricant).
8. Install the bonnet (7) into the body (17) and tighten the bonnet to 68N*m (600lb.*in).
9. Perform the adjustment procedure before installing in the system.

Troubleshooting

Warning: Relieve system pressure before any valve maintenance.

Symptom	Possible Causes	Corrective Action
Relief valve remains open	Leakage through bonded poppet seal (13)	Replace bonded poppet (12)
Relief valve opens below set pressure	Loss of spring force/Mechanical grip.	Remove adjustment cap (2). Clean spring (4), bonnet (7) and adjustment cap (2) from particles.
Relief valve opens above set pressure	Friction on the mechanical working mechanism. Leakage through any attached auxiliary system such as emergency shutdown system, remote operators, etc.	Check auxiliary systems for leaks, and readjust pressure. Disassemble, clean parts and perform cracking pressure adjustment procedure.
Unable to control the valve for shut-off	The spring range is too low.	Choose H-900HP Series valve with higher-pressure range spring.
Unable to relieve the pressure from the system after cracking	Relief valve too small. Too much gas capacity to complete cycle.	Choose a larger size of Relief valve.

For oxygen applications, work shall be carried out according to the procedures for working with oxygen. In a case where spare kits are ordered for "oxygen clean" valves, such kits have to be ordered as oxygen clean.



H-900 HP SERIES HIGH-PRESSURE RELIEF VALVES



INTRODUCTION

The H-900HP Series Relief Valves are designed and tested in accordance with MSS standard SP-99-1994 (R2005) - (Instrument Valves). This type of valves is intended for use under extremely high operating pressures (ranging from 50 psig to 6000 psig) and in unfavorable working conditions, and can be implemented in either gas or liquid applications. The valves are manufactured from ASTM-A276 body construction, and are available in male and female NPT / BSPT pipe threads and LET-LOK (compression) connectors.

General

H-900HP series is a relief valve intended for use in high-pressure applications. The valve is normally closed and opens when the system pressure reaches a set level. It then returns to the closed position when the system pressure falls below the set level.

Features

- Made from St.St 316.
- Service pressure up to 6000 psig.
- Available set pressures between 50 psig and 6,000 psig (3.44 to 413.8 Bar).
- Color-coded springs for each pressure range
- Replaceable springs for a wide range of pressures
- Available in male and female NPT / BSPT pipe threads and LET-LOK (compression) connectors.
- Available sizes: 1/4" or 6mm.

Cleaning & Packaging

Every H-900HP series Relief valve is cleaned in accordance with Standard Cleaning and Packaging (procedure 8184). Oxygen Clean & Lubricant Free Cleaning and packaging, in accordance with Special Cleaning and Packaging (procedure 8185), is available as an option.

Testing

The designs of the HAM-LET H-900HP Series Relief Valves have been tested for proof, burst and leakage. Every relief valve is factory-tested for proper set and resealing performance.

SAFETY INSTRUCTIONS

General

- All installation and/or maintenance operations must be obtained when the system pressure is fully relieved.
- All installation and/or maintenance operations must follow User Manual Instructions.
- Use only appropriate tools, which are designed and built for the specific operation.
- Plan your action carefully in advance, especially when dealing with extreme temperature, pressure and corrosive materials.
- Use proper protection and safety devices during maintenance.

Volume considerations

While evaluating the volume to be relieved, all system volumes should be considered, i.e.: system lines, pumps, bulk tanks, etc.

Warning!

The system designer and user have the sole responsibility for selecting products suitable for their special application requirements, ensuring their safe and trouble-free installation, operation, and maintenance. Application details, material compatibility and product ratings should all be considered for each selected product. Improper selection, installation or use of products can cause property damage or personal injury.

All safety valves which are intended to be used by 'end users' located within the European Community must be 'CE' marked. The distributor of the valves bears the responsibility for the follow-up of the above-mentioned issue, in case he is not the 'end user'.



H-900 HP SERIES (Cont'd) HIGH-PRESSURE RELIEF VALVES



H-900 HP MATERIALS

No.	Part	Qty.	Valve Body Material
1	Cap Plug	1	PTFE
2	Label	1	PVC
3	Adjustment Cap	1	St.St 316
4	Spring	1	St.St. 302, 17-7PH
5	Lower Spring Button	1	St.St 316
6	Locking Nut	1	St.St 316
7	Bonnet	1	St.St 316
8	O-Ring	1	Fluorocarbon FKM
9	Quad Ring	1	Fluorocarbon FKM
10	Retaining Ring	1	PH15-7Mo
11	Poppet	1	St.St 316
12	Clamps Screw	1	St.St 316
13	O-Ring	1	Fluorocarbon FKM
14	Insert	1	St.St 316
15	Body	1	St.St 316

DIMENSIONS

Description	Connection / size		Dimensions mm:			
	inlet	outlet	H	N	S	L
H900-HP	1/4 LET-LOK®	1/4 LET-LOK®	37	39	50	105
H900-HP	6MM LET-LOK®	6MM LET-LOK®	37	39	50	105
H985-HP	1/4 Male NPT	1/4 Female NPT	32	30	40	100
H995-HP	1/4 Male NPT	1/4 LET-LOK®	32	39	50	100

NOMINAL CRACKING - PRESSURE RANGE

psig	Bars	Spring Designator	Color
50-350	24 - 3.4	A	White
350-750	24 - 51.5	B	Blue
750-1500	103 - 51.5	C	Gold
1500-2250	103 - 155	D	Turquoise
2250-3000	206 - 155	E	Green
3000-4000	206 - 275	F	Red
4000-5000	344 - 275	G	Silver
5000-6000	344 - 413	H	Black

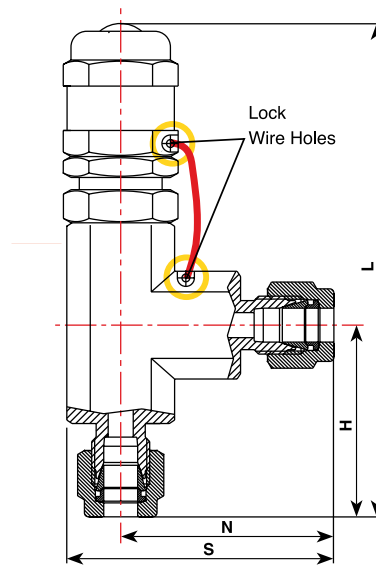
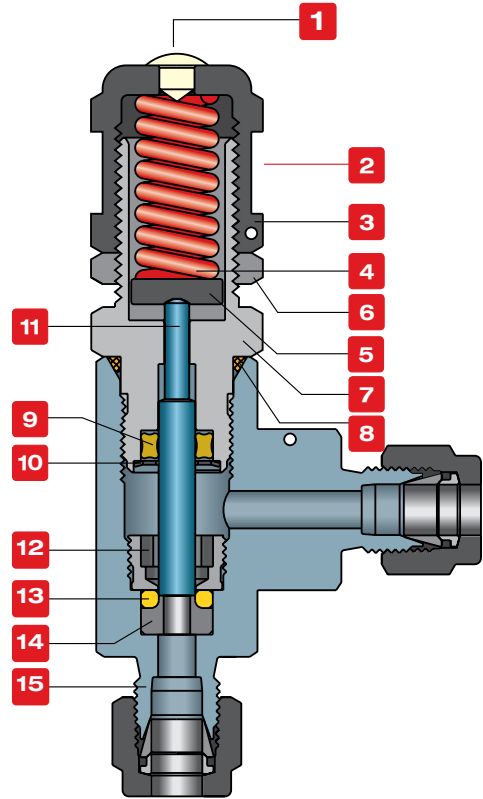
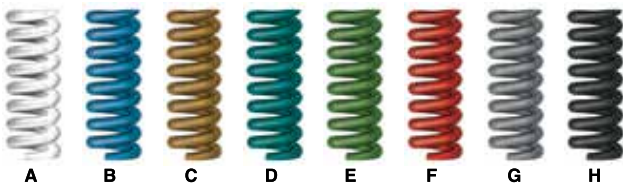



H-900 HP SERIES (Cont'd) HIGH-PRESSURE RELIEF VALVES



MAINTENANCE

Tool Requirement

- 3/4" wrench.
- 1/4" Allen (Hex) key.
- O-Ring installation and removal tools.
- Retaining ring installation and removal tool.

Cracking Pressure Adjustment

1. Thread the adjustment cap (3) onto the bonnet (7) - 9 full turns.
2. Tighten the locking nut (6) against the adjustment cap (3) and test for set pressure.
3. Relieve the system pressure; unthread the adjustment cap (3) as needed (use the manual or a 3/4" wrench). Repeat the procedure as necessary to obtain the desired set pressure.
 - 3.1 A clockwise rotation of the adjustment cap (3) will increase the spring force and the cracking pressure of the valve.
 - 3.2 A counter-clockwise rotation of the adjustment cap (3) will decrease the spring force and the cracking pressure of the valve.
4. Tighten the locking nut (6) against the adjustment cap (3).
5. Lock wire the adjustment cap (3) and the valve body (15) to maintain the relief setting.

H-900 HP Series

Spring Installation / Replacement

Warning: Relieve the system pressure before any valve maintenance.

Content:

- 1 x Spring (4)
- 1 x Label (3)
- 1 x Lock wire
- 1 x Lead

1. Select the desired spring according to the Nominal Cracking Pressure Range as shown at the "material of construction" section above.
2. Loosen the locking nut (6) with a 3/4" wrench (clockwise) and remove the adjustment cap (3) with a 3/4" wrench (counter-clockwise) from the bonnet (7).
3. Remove the spring (4).
4. Make sure all of the components are clean of burrs.
5. Insert the selected spring (4) inside the bonnet (7).

6. Replace the existing cracking pressure range label (2), with a new one. Ensure that the pressure range, which is written on the Label (2), is in compliance with the installed spring (4) range.
7. Screw the adjustment cap (3) onto the bonnet (7) with a 3/4" wrench.
8. Perform the Cracking Pressure Adjustment procedure described above.

Valve Testing Guidelines.

1. Connect the Relief valve's inlet to the pressure source.
2. Connect the Relief valve's outlet to any leak detecting device.
3. Increase the inlet pressure slowly.
4. Verify that an initial flow from the outlet will occur at the pre-set pressure.
5. Repeat the adjustment procedure as necessary to set the desired cracking pressure.

Note:

For proper maintenance of the H-900HP Series Relief Valves, a service cycle and setting validation of at least once each 1/2 year is recommended. The inspection, maintenance and testing can be incorporated into the annual inspection procedure to ensure proper operation and many years of trouble-free service.

The life span of the main valve seal depends upon varied factors, such as:

- Chemical resistance of the seal to the system medium
- The volume of fluid, passed through the valve.
- The operating pressure
- The quantity of dirt and other foreign particles present.

H-900 HP SERIES SEAL KIT REPLACEMENT.

Content:

- 1 x O-Ring (8)
- 1 x Quad-ring (9)
- 1 x Retaining ring (10)
- 1 x O-Ring (13)

Oxygen Applications

For oxygen applications, work shall be carried out according to the procedures for working with oxygen. In a case where spare kits are ordered for "oxygen clean" valves, such kits have to be ordered as "oxygen clean" by adding "-OC" designator. Example: Z-900-HP-SK-1/4-VI-OC



H-900 HP SERIES (Cont'd) HIGH-PRESSURE RELIEF VALVES



Disassembly and Seal Removal

Warning: Relieve the system pressure before any valve maintenance.

1. Clamp the valve body in a vise.
2. Remove the adjustment cap (3).
3. Remove the bonnet (7) from the body (15) - use a 3/4" wrench and rotate counter-clockwise for opening.
4. Remove the poppet (11) by pulling it from the bonnet (7) bore.
5. Remove the O-ring (8) from the bonnet (7).
6. Remove carefully the retaining ring (10) from the bonnet (7).

Caution: The retaining ring is a spring stainless clip. Do not direct it at a person.

7. Remove the Quad-ring (9) from the bonnet (7).
8. Remove the clamp screw (12) from the body (15). Rotate the clamp screw counter-clockwise for opening. Use a 1/4" Allen (hex) key.
9. Remove the O-ring (13) from the body (7).
10. Discard all soft (wetted) parts.
11. Inspect all parts for nicks, scratches and dents.

Discard as appropriate. Replace with HAM-LET parts only

Reassembly And Seal Installation

1. Clamp the valve body in a vise.
2. Make sure all parts are clean before installation.
3. Install a new O-ring (13) in the body (7) (lubricate with system compatible lubricant).
4. Thread clamp screw (12) in the body (15). Tight permanently with 1/4" Allen (hex) key.
5. Install new quad-ring (9) (Lubricate with system compatible lubricant) into the bonnet (7).
6. Install new retaining ring (10) (make sure the teeth are pointing away from the quad-ring).
7. Insert the poppet (11) into the bonnet (7) through the quadring (9) until it bottoms.
8. Install new o-ring (8) on the bonnet (7) (Lubricate with system compatible lubricant).
9. Install the bonnet (7) into body (15) and tighten bonnet to 68N*m (600lb.*in).
10. Perform the adjustment procedure before installing in the system.

Troubleshooting

Warning: Relieve system pressure before any valve maintenance.

Symptom	Possible Causes	Corrective Action
Relief valve remains open	Leakage through O-Ring seal (13)	Replace O-Ring (13)
Relief valve opens below set pressure	Loss of spring force/ Mechanical grip.	Remove adjustment cap (3). Clean spring (4), bonnet (7) and adjustment cap (3) from particles.
Relief valve opens above set pressure	Friction on the mechanical working mechanism. Leakage through any attached auxiliary system such as emergency shutdown system, remote operators, etc.	Check auxiliary systems for leaks, and readjust pressure. Disassemble, clean parts and perform cracking pressure adjustment procedure.
Unable to control the valve for cracking	The spring range is too high.	Choose a spring with lower pressure range.
Unable to control the valve for shut-off	The spring range is too low.	Choose a spring with higher-pressure range.
Unable to relieve the pressure from the system after cracking	Relief valve too small. Too much gas capacity to complete cycle.	Choose a larger size of Relief valve.

■ For oxygen applications, work should be carried out according to the procedures for working with oxygen. In a case where spare kits are ordered for "oxygen clean" valves, such kits have to be ordered as oxygen clean.